

30

Netter Hydraulic External Vibrators Series CC, CV, CCV and DV

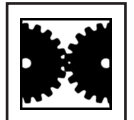

- Driven by flanged hydraulic motor
- Nominal frequency from 1.750 min^{-1} to 5.400 min^{-1}
- Centrifugal force from 7.320 N to 49.210 N
- Frequency continuously adjustable by hydraulic pressure
- High working moment, high amplitude
- Low unit weight combined with high capacity
- Mounting by attachment screw (CCV), bracket (CC) or flange (CV/DV)



CV 2.8



CC 2.8



CCV 6



DV 6



Netter Hydraulic External Vibrators Series CC, CV, CCV and DV

Type	Unbalance adjustment **	Working moment [cmkg]	Starting pressure [bar]	Frequency* [U/min]	Volume flow [l/min]	Centrifugal force [N]	Frequency* [U/min]	Volume flow [l/min]	Centrifugal force [N]
CC2.8-5HB	1	18,3	13	2.700	15,5	7.320	4.400	26,5	19.430
	2	18,0	12	2.800	15,9	7.740	4.500	25,7	19.990
CV2.8-5HB	3	16,9	10	2.800	17,0	7.270	4.600	26,9	19.610
CCV 4-5HB	4	15,3	9	3.300	18,9	9.140	4.800	27,3	19.330
DV 4-5HB	5	12,8	9	3.800	21,6	10.140	5.000	28,8	17.550
	6	9,8	7	4.000	22,7	8.600	5.400	30,3	15.670
CCV6-12-8HA	0 - 100 %	28	8	2.750	34,0	11.610	3.500	45,8	18.810
DV6-12-8HA									
CCV6-25-8HA	0 - 100 %	59	9	2.500	30,7	20.220	3.900	43,5	49.210
DV6-25-8HA									
CCV6-50-8HA	0 - 100 %	119	11	1.750	23,5	19.980	2.600	34,1	44.110
DV6-50-8HA									

CC = mounting with bracket NVH
CCV = mounting with attachment screw

DV/CV = mounting with flange screw
5 HB/8 HA = hydraulic motor

* Notice: Hydraulic external vibrators for higher frequency see leaflet series NHG.

**The working moment of series CC, CV, CCV and DV 2.8/4 is adjustable in 6 steps.

Type	A [mm]	B [mm]	C [mm]	D [mm]	E [mm]	F [mm]	G [mm]	H [mm]	Outlet J	Inlet K
CV 2.8	250,8	174,6	249,2	203,2	76,2	87,3	23,8	22,0	3/4"	1/2"
CC 2.8	228,6	181,0	241,3	-	76,2	87,3	-	-	3/4"	1/2"
CCV 4	292,1	209,6	244,5	209,6	23,8	104,8	-	-	3/4"	1/2"
DV 4	304,8	206,4	244,5	4 bores: 63,5 x 266,7	101,6	101,6	22,2	16,5	3/4"	1/2"
CCV 6	368,3	287,3	320,7	285,8	25,4	142,9	-	-	3/4"	1/2"
DV 6	457,2	279,4	320,7	6 bores: 50,8 x 50,8 x 406,4	152,4	141,3	28,6	22,0	3/4"	1/2"

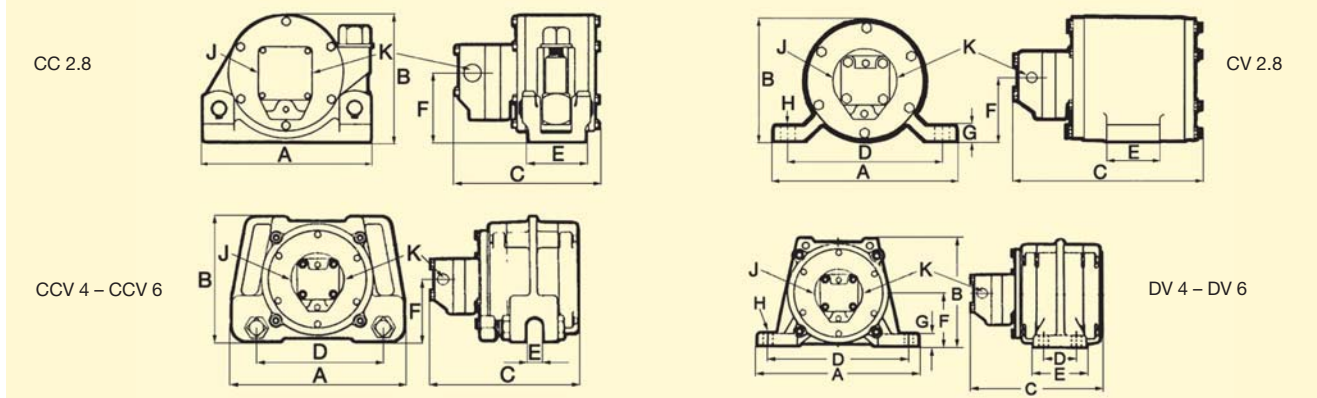

Application

Netter hydraulic external vibrators series CV, CC, CCV and DV are especially suitable to unload rail wagons and bulk hoppers as well as for the sieving and compacting of different materials.

Trucks and tractors which use hydraulic energy for dumping and lifting, are sources of hydraulic power.

A special feature of CC/CCV vibrators is the quick manual repositioning.

Design and functioning principle

The vibration (circular) is produced by unbalance pairs with double bearings.

The frequency and thus the centrifugal force are continuously adjustable by the volume flow. The hydraulic external vibrators generate high amplitudes with low frequencies.

The working moment of series CC, CV, CCV and DV 2.8/4 is adjustable in 6 steps. The working moment of series DV 6-12,

-25 and -50 is continuously adjustable. The only difference between the units is the execution of the housings. The vibrators generate very high forces in proportion to their weight.

Permissible operating conditions

Drive medium:

Hydraulic oil (clean and filtered)
DIN 51524/25 or motor oil DIN 51511

Operating pressure:

Max. 80 bar inlet,
max. 2 bar outlet.

Ambient temperature:

-20°C to 60°C

NetterVibration offers the accessories required for the mounting, installation and control of vibrators and interval impactors.

Netter provides solutions.

Consult our experienced application technicians.

Netter GmbH

Germany

Fritz-Ullmann-Str. 9
55252 Mainz-Kastel
Tel. +49 6134 2901-0
Fax +49 6134 2901-33

Switzerland

Erlenweg 4
4310 Rheinfelden
Tel. +41 61 8316200
Fax +41 61 8311291

Poland

Al. W. Korfatego 195/17
40-153 Katowice
Tel. +48 32 2050947
Fax +48 32 2051572

www.NetterVibration.com
info@NetterVibration.com