

32

## Netter Hydraulic External Vibrators Series NHG L

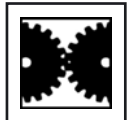

- Rotary vibration
- Nominal frequency from 3.500 min<sup>-1</sup> to 7.000 min<sup>-1</sup>
- Centrifugal force from 4.070 N to 25.600 N
- Frequency continuously variable via volume flow rate



NHG 500 L



NHG 3000 L



# NetterVibration



## Netter Hydraulic External Vibrators Series NHG L

Type	Working moment [cmkg]	Normal Operation ED 100%			Short Operation ED ≤ 60%			Weight [kg]
		Frequency [U/min]	Centrifugal Force [N]	Oil Requirement [l/min]	Frequency [U/min]	Centrifugal Force [N]	Oil Requirement [l/min]	
NHG 500 L	2,06	6.000	4.070	12	7.000	5.550	14	6,4
NHG 600 R L	0 to 3	6.000	5.922	12	7.000	5.723*	14	8,2
NHG 900 L	6,64	4.000	5.870	8	5.000	9.100	10	7,7
NHG 3000 L	29,18	3.500	19.600	20	4.000	25.600	22	29,0

\*The working moment must be reset to 2.19 cmkg.

Type	A [mm]	B [mm]	C [mm]	D [mm]	E [mm]	F [mm]	Ø G [mm]	H [mm]	I [mm]	K [mm]	Ø L [mm]	M [mm]	Ø P [mm]	Ø R [mm]
NHG 500 L NHG 600 R L NHG 900 L	194	120	120	160	24	36	17	212	80	37	G1/4	47	G1/4	G3/8
NHG 3000 L	260	190 (210)	140	200	30	60 (80)	17	320	70	50	G1/8	94 (114)	G3/8	G1/2

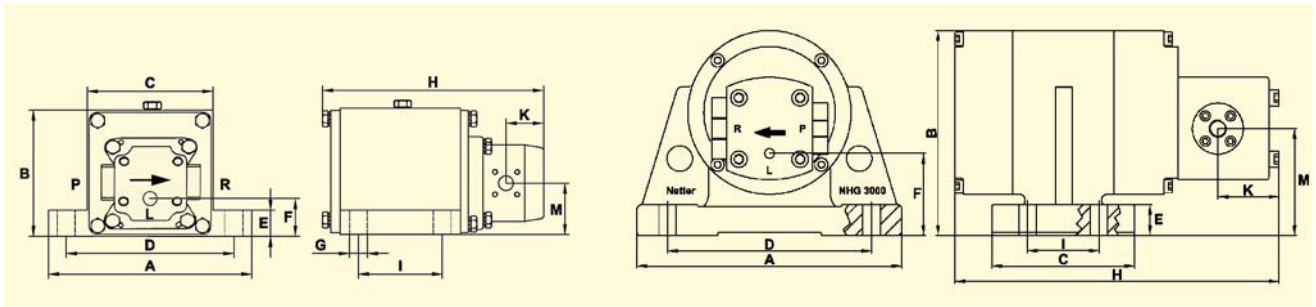

NHG 500 L, NHG 600 R L and NHG 900 L

NHG 3000 L



NHG 3000 L



Emptying silo vehicles



NHG 900 L

### Applications

Series NHG L hydraulic external vibrators are particularly suitable for emptying containers and bulk material hoppers containing adherent bulk materials, for preventing bridging and tubing and for compacting various materials. A special characteristic is its use for unloading transport vehicles, e.g. trucks, silo buses and ships. The vibrators are driven via the hydraulic system belonging to the carrier vehicle, and are therefore independent of any external energy supply.

### Design and functioning principle

The rotary vibration is created by an unbalance. High rotational speeds result in large centrifugal forces. The rotational speed, and hence the centrifugal force, can be regulated continuously via the volume flow rate. NHG 500 L, NHG 900 L and NHG 3000 L have fixed working moments. The working moment of the NHG 600 RL can be adjusted in steps, from the outside.

Series NHG L hydraulic external vibrators are also available without an overflow oil line connection.

The pressure in the return line must not exceed 2 bar.

### Permissible operating conditions:

#### Drive Medium:

Clean, filtered hydraulic oil DIN 51524/25 or engine oil DIN 51511

#### Operating pressure:

Pressure side 200 bar max.  
Overflow oil line back pressure 2 bar max.

#### Ambient temperature:

-20°C to 80°C  
-20°C to 60°C NHG 3000

NetterVibration offers the accessories required for mounting, installation and control of vibrators and interval impactors.

**Netter provides solutions.  
Consult our experienced application technicians.**

### Netter GmbH

#### Germany

Fritz-Ullmann-Str. 9  
55252 Mainz-Kastel  
Tel. +49 6134 2901-0  
Fax +49 6134 2901-33

#### Switzerland

Erlenweg 4  
4310 Rheinfelden  
Tel. +41 61 8316200  
Fax +41 61 8311291

#### Poland

Al. W. Korfatego 195/17  
40-153 Katowice  
Tel. +48 32 2050947  
Fax +48 32 2051572

www.[NetterVibration.com](http://NetterVibration.com)  
info@[NetterVibration.com](mailto:NetterVibration.com)