



40

Netter Vibrating Cross Series NKH and NKM



- Compacting of dry refractory mass for induction furnace
- Constant, effective compaction
- Solid in-tension, vibration of the total mould
- Manual or hydraulic tightening according to selected type
- Compacting in a few minutes
- Same vibrator also for bottom



NKM (manual)



NKH (hydraulic)



Netter Vibrating Cross Series NKH and NKM

Type	Mould diameter [mm]	Weight without vibrator [kg]	A [mm]		B [mm]		C [mm]		D [mm]	E [mm]	F [mm]	
			min	max.	min	max.	min	max.			NKH	NKM
NKH, NKM 300	400- 600	33	360	390	312	342	300	330	150	46±1	550	400
NKH, NKM 400	500- 700	37	460	490	412	442	400	430	150	46±1	550	400
NKH, NKM 500	600- 800	40	560	590	512	542	500	530	150	46±1	550	400
NKH, NKM 800	920-1160	72	860	890	812	842	800	830	150	46±1	550	555
NKH, NKM 900	1120-1240	124	1060	1100	917	957	900	940	150	46±1	810	660

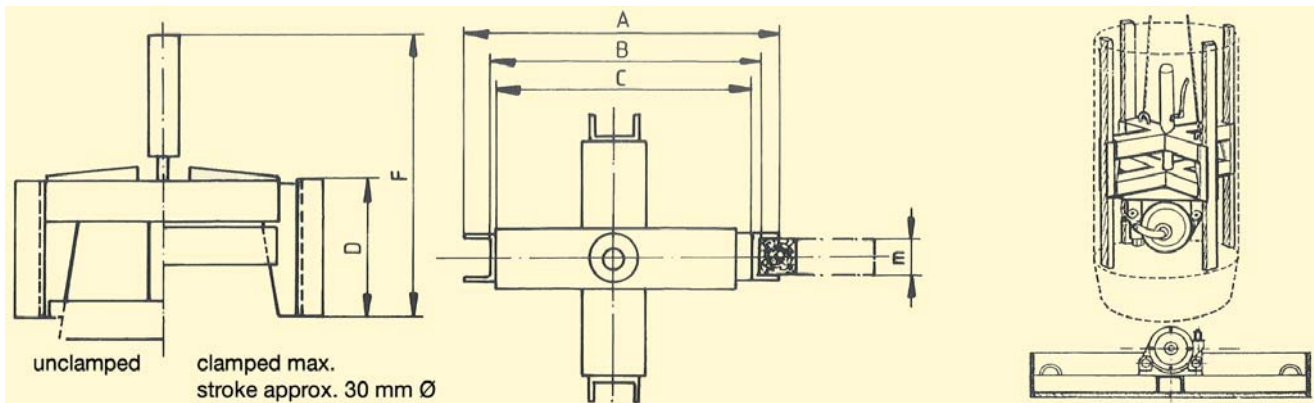

Vibrator	Working moment [cmkg]	Air consumption [l/min]	Weight [kg]	Nominal frequency [min ⁻¹]	Centrifugal force [N]
NVT 105	5,40	1.800	16,3	14.500	62.260

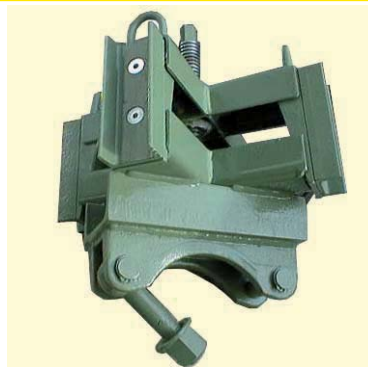

Applications

Netter vibrating crosses of NKH and NKM series are used for compacting dry refractory mass in induction furnaces.

Design and Working Principle

The Netter vibrating cross consists of a cross-shaped clamping fixture and a pneumatic external vibrator of NVT series. The vibrator is attached to the cross by a quick-clamping device of the NVH 4 series.

The cross is tightened either manually by means of a shaft (NKM) or by a hydraulic cylinder (NKH). When tightened, the 4 clamping jaws extend equally.

Hardwood battens, laid between the vibrating cross and the wall of the stamping mould, assure the adjustment of the vibrating cross as well as the constant power transmission. The compaction is caused by the vibrating motion of the complete mould. The bottom can also be compacted by using the same vibrator mounted on a base-plate.

NetterVibration offers the accessories required for the mounting, installation and control of vibrators and interval impactors.

Netter provides solutions. Consult our experienced application technicians.

Netter GmbH

Germany

Fritz-Ullmann-Str. 9
55252 Mainz-Kastel
Tel. +49 6134 2901-0
Fax +49 6134 2901-33

Switzerland

Erlenweg 4
4310 Rheinfelden
Tel. +41 61 8316200
Fax +41 61 8311291

Poland

Al. W. Korfatego 195/17
40-153 Katowice
Tel. +48 32 2050947
Fax +48 32 2051572

www.NetterVibration.com
info@NetterVibration.com