

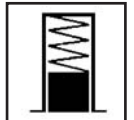

27

Netter Pneumatic Impactors Series PKL



- Higher impact power than traditional impactors
- Lower compressed air requirement per impact
- Low-noise versions with elastomer insert EE
- Versions with automatic control ST
- ATEX or stainless steel versions available



PKL 150



PKL 170



PKL 220



NetterVibration



Netter Pneumatic Impactors Series PKL

Type	Optimum operating pressure [bar]	Impact force* [kg]	Air requirement/impact at optimum pressure [Normal litre]	Weight [kg]	Suitable for wall thickness [mm]
PKL 125/4	4,0	0,43	0,09	0,8	1 – 2
PKL 125/6	6,0	0,60	0,14	0,8	1 – 2
PKL 135/4	4,2	0,56	0,13	1,5	1 – 3
PKL 135/6	5,9	0,92	0,18	1,5	1 – 3
PKL 150/3	2,9	1,30	0,27	2,6	2 – 4
PKL 150/4	4,1	1,80	0,38	2,6	2 – 4
PKL 150/5	4,7	2,10	0,43	2,6	2 – 4
PKL 150/6	5,9	2,70	0,54	2,6	2 – 4
PKL 170/3	3,7	4,20	0,95	10,4	3 – 5
PKL 170/5	5,5	6,30	1,41	10,5	3 – 5
PKL 200/3	3,6	4,85	2,16	19,8	4 – 8
PKL 200/5	5,4	7,55	2,40	19,9	4 – 8
PKL 220/4	4,0	5,50	1,43	8,5	8 – 10
PKL 220/6	6,0	8,80	2,10	8,6	8 – 12
PKL 240/4	4,0	12,40	2,00	24,0	10 – 12
PKL 240/6	6,0	16,60	3,01	24,1	> 10
PKL 240/8	8,0	19,30	3,97	24,2	> 10

*The impact corresponds to the effect of the given weight, when dropped from a height of 1 m.

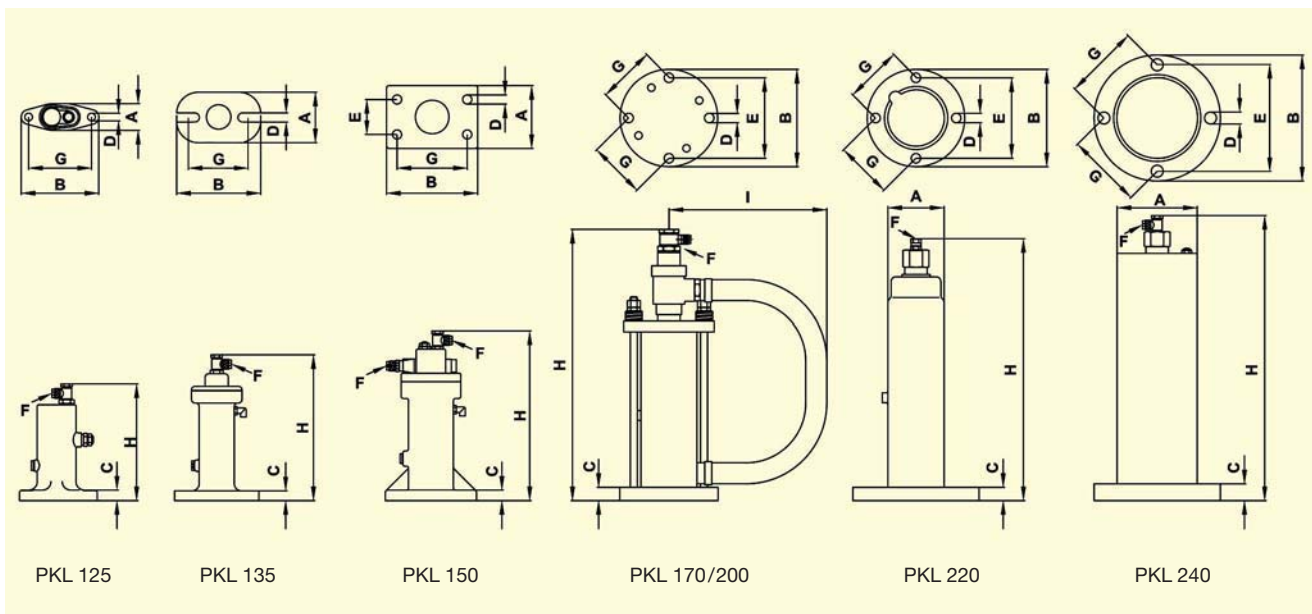

Type	A [mm]	B [mm]	C [mm]	Ø D [mm]	E [mm]	F	G [mm]	H [mm]	I [mm]
PKL 125	38	111	15	9,0	–	G1/8, NW 6×1	90,0	167	–
PKL 135	72	120	14	13,0	–	G1/8, NW 6×1	90,0	204	–
PKL 150	90	130	15	12,5	50	G1/8, NW 6×1	100,0	240	–
PKL 170	–	Ø 140	19	13,5	Ø 115	G1/2, NW 6×1	81,5	397	~ 230
PKL 200	–	Ø 180	24	17,0	Ø 152	G1/2, NW 6×1	107,5	425	~ 230
PKL 220**	Ø 80	Ø 140/180	18/22	13,5/17,0	Ø 115/152	G1/8, NW 6×1	81,5/107,5	380/384	–
PKL 240	Ø 114	Ø 180	27	17,0	Ø 152	G1/8, NW 6×1	107,5	405	–

** Optionally available with fixing dimensions as for PKL 170 or PKL 200

Netter Pneumatic Impactors Series PKL



ST Kit

Applications

The ST kit enables a continuous impact sequence when connected to a permanent compressed air supply.

Impact Frequency

The impact frequency can be adjusted by means of a throttle valve installed in the air supply line. The maximum impact sequence must be observed.



EE Kit

Applications

The EE kit is used to produce a low-noise impact or "rubber hammer effect".

Design and Function

A spacer plate with an elastomer insert, is installed between the impactor and the mounting surface of models PKL 125, 135 and 150.

From model PKL upwards, the existing impact plate is replaced by an impact plate with an integrated elastomer insert. The noise level is considerably reduced by the elastomer disc.



Special Versions ATEX / Stainless Steel / High Temperature

PKL E (ATEX)

Netter series PKL E pneumatic impactors comply with directive 94/9/EC (ATEX product directive) device group II and are suitable for use in potentially explosive areas of category 2 (2G and 2D 85°C[T6]) in zones 1, 2, 21 and 22.

PKL S (Stainless Steel)

Stainless steel intermittent impactors satisfy the specific requirements for chemical resistance of the surfaces.

PKL HT (High Temperature)

The HT series is designed for use at ambient temperatures of up to 160°C.



Weld-On Consoles

Applications

Weld-on brackets ASB and weld-on plates ASP, available as straight or round versions, are suitable for attachment to square, round and conical containers.

They allow optimum transfer of the impulses produced by the impactor, while reducing the loads on weld seams and container walls.

Design and Function

The weld-on consoles are welded directly to the container. The impactor is then screwed to the console using fixing set NBS.



Fixing Sets NBS

Applications

NBS fixing sets provide a safe and permanent fixing of PKL impactors.

NBS fixing sets consist of special screws,

damping elements, washers and nuts, to suit the respective application.

The fixing sets are available in different executions.



Control Valves

Applications

Directional control valves are necessary for the control of impactors.

They can be activated either by hand or by means of an electronic timer.

Our product range includes electric, pneumatic and manually operated valves.



Electronic Timer AP and PAP

Applications

Electronic timers are used for the control of impactors, solenoid valves and contactors, wherever a process requires variable timing.

Design and Function

The adjustable duty time or pause time of the AP 115 has a control function by means of an electric signal (e.g. to a solenoid valve). The pneumatic duty-pause controls (PAP 115 and PAP 116) directly control the compressed air supplied to the system and can be used in wet areas.

Controlling the duty time reduces energy consumption and noise levels.



Netter Pneumatic Impactors Series PKL



Insulation hoods

Applications

The use of hoods is particularly worthwhile for bunkers with insulation covers.

Attaching the insulation hood to the insulation cover fully insulates the source of the noise (bunker).



Vacuum Fixing Devices VAC

Applications

Series VAC vacuum fixing devices serve the fast fixation of impactors on smooth or, under certain circumstances, rough or curved surfaces. They allow quick and simple attachment without welding or screwing.

Design and Function

As soon as compressed air is supplied to the VAC mounting, the device is sucked tight, ensuring a force-locked connection between the impactor and the mounting surface. ATEX compliant mountings and units with stainless steel plates are available.



Cleaning filters



Cleaning bunker walls



Cleaning weighing containers

Applications

Series PKL pneumatic impactors are particularly suitable for knocking stubborn residues from walls, pipes and containers.

Examples of applications include: elimination of tube-forming, bridging and evacuation of residues.

Design and Function

The impact (similar to a hammer) is created by the piston. With PKL 125 to 150 the impact is produced directly against the surface upon which the impactor is mounted.

From PKL 170 upwards the impact is produced against the base plate. The compressed air pushes the piston against one or two springs. The fast exhausting of the piston chamber causes the piston to strike abruptly against the impact surface.

Series PKL impactors can be operated using non-lubricated compressed air. A directional control valve is necessary for

activation (not included). The maximum impact sequence is 10 impacts in a row, at a rate of 15 impacts per minute and 180 impacts per hour.

Permissible Operating Conditions:

Drive Medium:

Compressed air or nitrogen (filter $\leq 5 \mu\text{m}$), Preferably with oil mist

Operating Pressure:

2,5 bar to 6 bar

Ambient Temperature:

-20°C to 60°C

HT version up to 160°C

NetterVibration offers the accessories required for the mounting, installation and control of vibrators and interval impactors.

Netter provides solutions.

Consult our experienced application technicians.

Netter GmbH

Germany

Fritz-Ullmann-Str. 9
55252 Mainz-Kastel
Tel. +49 6134 2901-0
Fax +49 6134 2901-33

Switzerland

Erlenweg 4
4310 Rheinfelden
Tel. +41 61 8316200
Fax +41 61 8311291

Poland

Al. W. Korfatego 195/17
40-153 Katowice
Tel. +48 32 2050947
Fax +48 32 2051572

www.NetterVibration.com
info@NetterVibration.com