

These operating instructions apply to:



Pneumatic turbine vibrators

NCT 1	NCT 15
NCT 2	NCT 29
NCT 3	NCT 55
NCT 4	NCT 108
NCT 5	NCT 126
NCT 10	NCT 250



Pneumatic ball vibrators

NCB 1	NCB 10
NCB 2	NCB 20
NCB 3	NCB 50
NCB 5	NCB 70



Pneumatic roller vibrators

NCR 3	NCR 57
NCR 10	NCR 120
NCR 22	

Use and storage

Before installing the vibrators read these instructions carefully. It is the basis for any action when dealing with the vibrators, and may be used for training purposes. The instructions should be subsequently stored at the operation site.

Copyright

This documentation is protected by copyright. **NetterVibration** reserves all rights such as translations, reprinting and reproduction of the instructions, as well as parts thereof.

1 General information

Designation	The pneumatic vibrators of the series NCT, NCB und NCR are hereafter referred to as "vibrators".
Scope of delivery	Please refer to the delivery note for the scope of delivery. Check the packaging for possible transport damage. In the event of damage to the packaging, check the contents for completeness and possible damage. Inform the carrier in the case of damage.
Target group	The target group for these instructions is technical staff, who have basic knowledge in pneumatics and mechanics. Only complying technical staff may work on the vibrators. The vibrators may only be installed, put into operation, maintained, troubleshoot and disassembled by persons authorised by the operator.
Limitation of liability	All technical information, data and instructions for installation, operation and maintenance in these instructions are based on the latest information available at the time of printing and take our past experience to the best of our knowledge into account. No claims can be derived from the information, illustrations and descriptions in these operating instructions. The manufacturer does not assume liability for damages resulting from: <ul style="list-style-type: none">• failure to observe the instructions,• improper use,• unauthorised repairs,• technical modifications,• use of non-permissible spare parts. Translations are made to the best of our knowledge. NetterVibration does not assume liability for translation errors, even if the translation was made by us or on our behalf. Only the original German text remains binding.
Model designations	Explanation of additions to names in model designations: HT: models for ambient temperatures up to 200 °C NCR..M 1: models for ambient temperatures up to 300 °C NCR..M 500: models for ambient temperatures up to 500 °C NCT..S: stainless steel models NCT..i: models with higher centrifugal force NCR..P: models with plastic cover
Directives / standards observed	The pneumatic vibrators of the series NCT, NCB und NCR comply with the following directives and regulations: <ul style="list-style-type: none">• EC Machinery Directive 2006/42/EC• Supply of Machinery (Safety) Regulations 2008 (UK) In particular, the standard EN ISO 12100 has been observed.

2 Safety

Intended use	<p>The vibrators are designed for installation in machines.</p> <p>General applications are: loosening, conveying, sorting, compacting, separating bulk materials and reducing friction. The vibrators are used for emptying bunkers, as drives for conveyor troughs, as sieves and vibrating tables.</p> <p>The vibrators may also be used outdoors, in dusty and humid environments.</p> <p>After consultation with NetterVibration the NCT may also be used in water or other liquids.</p> <p>Any other use is considered improper.</p>
Qualification of qualified personnel	<p>Installation, commissioning, maintenance and troubleshooting of the vibrators may only be performed by authorised qualified personnel, who have basic knowledge in pneumatics and mechanics.</p> <p>All handling of the vibrators is the responsibility of the operator.</p>

WARNING

Compressed air

A loosened hose which is under pressure can lead to personal injuries.

- Screw the hose lines on carefully.
- Check the hose lines and connections after one hour of operation and thereafter regularly (generally monthly).
- Retighten the hose lines, if necessary.
- Ensure that the compressed air is disconnected from the supply lines during all work on the vibrators.
- Prevent the vibrators from being switched back on during all work.

WARNING

Falling parts

The vibrators, construction parts as well as fastening screws can come loose due to vibration. Falling parts lead to severe personal injuries.

- Check the fastening screws after one hour of operation and thereafter at regular intervals (generally monthly).
- Retighten the fastening screws, if necessary.
- A safety device with a safety cable is mandatory for critical mounting situations.

WARNING

Sound level

Near the vibrators the sound pressure level may exceed 80 dB(A). The human ear can be permanently damaged by the high sound level.

- Use suitable ear protection if 80 dB(A) is exceeded.
- vibrators may only be operated with silencer.

⚠ CAUTION

Risk of burns due to hot surfaces

At high ambient temperatures, housing surfaces and compressed air lines can become very hot and cause burns when touched.

- Do not touch housing surfaces and compressed air lines of the vibrators.
- Only operate the vibrators within the permissible ambient temperature, according to Chap. Technical data, page 4.

NOTICE

Operation of the vibrators with silencers is mandatory.
Silencers reduce the noise level and protect the vibrators from contamination entering.

3 Technical data

Permissible operating conditions

Drive medium	NCT must be operated with clean compressed air or nitrogen according to the following specification, according ISO 8573-1 :		
	[5 :	6 :	2]
	Filter ≤ 5 µm	Humidity, pressure-dew point ≤ +10 °C	Total oil content ≤ 0,1 mg/m ³
	NCB and NCR must be operated with clean compressed air or nitrogen according to the following specification, according ISO 8573-1 :		
	[5 :	6 :	4]
	Filter ≤ 5 µm	Humidity, pressure-dew point ≤ +10 °C	Total oil content ≤ 5 mg/m ³
	All vibrators can be operated oil-free. A mist lubricator extends the service life of the NCB and NCR . When operating in high ambient temperatures, the use of a mist lubricator with special high-temperature lubricant (up to max. 300 °C) extends the service life of the NCR..M 1 and NCR..M 500 .		
Ambient temperature	Standard: -20 °C to 120 °C	NCT..HT: 80 °C to 200 °C	NCB..HT: -20 °C to 200 °C
	NCR..HT: -20 °C to 200 °C	NCR..M 1: -20 °C to 300 °C	NCR..M 500: 20 °C to 500 °C
Important: For NCT HT -models the performance is reduced below the specified ambient temperature (< 80 °C).			
Operating pressure	2,0 to 6,0 bar		
Max. frequency NCT	The maximum permissible frequency must not be exceeded.		

Further technical data can be found in the brochures of the NCT, NCB and NCR on www.NetterVibration.com.

Sound level

The sound level is largely determined by the mounting surface (e.g. sheet metal) on which the vibrator is mounted. Depending on the type, the sound pressure level with a silencer is 75 - 85 dB(A) at 6 bar air pressure, at lower air pressure it is below this. Sheet metal which is not silenced increases the sound level.

Connection data

Typ	Thread	Tightening torque* [Nm]	Connection thread [inch]	Minimum hose size**	Valve size [inch]
NCT 1, 2, 3, 4 / NCB 1, 2 / NCR 3	M6	10	G 1/8	DN 6	1/4
NCT 5, 10, 15, 29 NCB 3, 5, 10, 20 / NCR 10, 22	M8	25	G 1/4	DN 6	1/4
NCB 50, 70	M10	50	G 3/8	DN 9	1/4
NCR 57	M12	87	G 3/8	DN 9	1/4
NCT 55, 108	M12	87	G 3/8	DN 12	1/2
NCR 120	M16	210	G 3/8	DN 9	1/4
NCT 126, 250	M16	210	G 3/8	DN 12	1/2

* Screws and nuts of the strength class 8.8 (sliding friction coefficient 0.14)

** DN = Diameter nominal (inner diameter)

4 Design and function

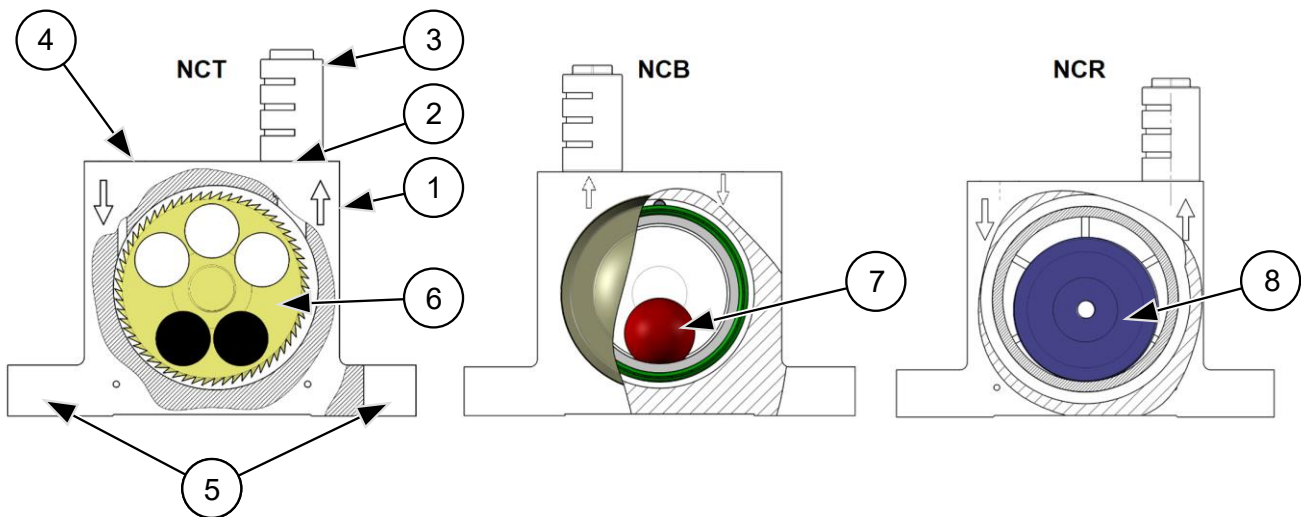

- 1 Housing
- 2 Air outlet
- 3 Silencer

- 4 Air inlet
- 5 Mounting slots
- 6 Turbine with unbalances

- 7 Steel ball
- 8 Steel roller

Function

The vibrators generate circular vibrations, i.e. the vibrations act in all directions of a plane.

The air inlet (4) and the air outlet (2) are indicated by arrows on the housing (1).

The silencer (3) reduces the sound level and protects the interior of the housing from impurity. The frequency and therefore also the centrifugal force are determined by the pressure of the drive medium.

Two mounting slots (5) are provided for fastening.

NCT: A turbine (6) rotates in the housing with eccentrically inserted unbalances. Depending on the type, a different number of unbalances are pressed into the turbine, so that different unbalances are possible for each housing size. The turbine is mounted in permanently lubricated rolling bearings. These are fitted in the housing and cover.

NCB: The vibration (circular oscillation) is generated by the centrifugal force of a rotating steel ball (7) which runs on a hardened steel race. The housing is closed by a pressed-in cover.

NCR: The vibration (circular oscillation) is generated by the centrifugal force of a rotating steel roller (8) that runs in the housing on an inner ring made of steel.

5 Transport and storage

Transport conditions

Special conditions of transport are not required.

Storage conditions

Storage in a dry and clean environment, protected from UV-exposures, weather and ozone. Storage temperature: -20 °C to 60 °C.

Close all openings before storage.

6 Installation



Observe the safety instructions in chap. Safety, starting on page 3.

Standard installation

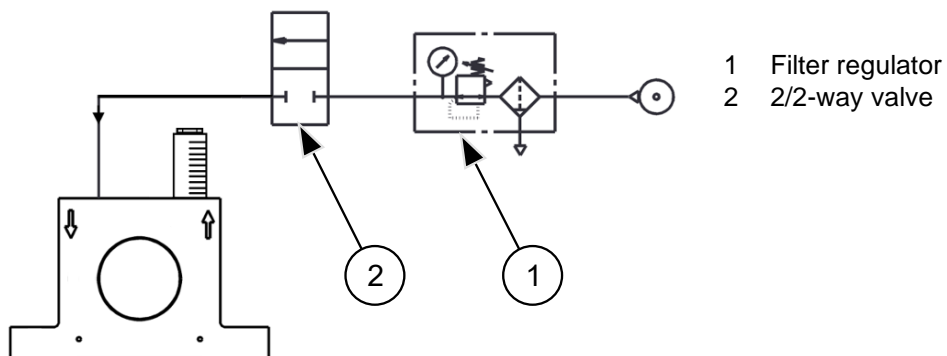

The vibrators can be operated with 3/2- or 2/2-way valves. The filter regulator can be used to set the operating pressure desired and thereby the frequency.

1. Mount the vibrators with two fastening screws and self-locking washers on a clean and flat surface (flatness of $\pm 0,1$ mm). **NetterVibration** recommends placing the vibrators on a reinforcement profile (U-profile or suitable console). Weld the reinforcement profile to the mounting surface provided by the customer so that the vibration energy is optimally distributed.

Lubricate the screws with a suitable assembly paste.

Observe the recommended values for screw sizes and tightening torques.

Mounting on U-profile

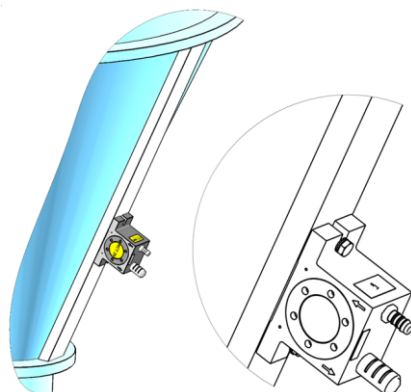

Mounting on weld-on console

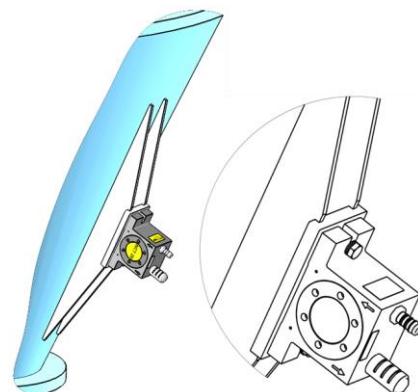

2. Mount the maintenance unit (filter, regulator), valve and supply line. Observe the minimum cross-sections for valves and hoses.

3. Fasten the compressed air supply. The air inlet has a smaller opening than the air outlet. Both are indicated by arrows on the front.
Air resistance increases with hose length. The nominal widths given above apply to hose lengths up to 3 m. Longer lines require larger cross sections. When used in high ambient temperatures, use suitable heat-resistant hoses and connections.
The escaping air can be discharged via a hose. If the vibrator is to achieve full output, the exhaust air hose must have a larger nominal diameter than the supply hose. The use of the supplied silencer is mandatory. The silencer must be mounted at the free end.
Rainwater or any other liquid must not enter the housing when using outdoors. Is there a risk that e.g. Rainwater runs into the housing through the air outlet, the exhaust air must be discharged through a hose bent downwards.
4. For critical installation situations secure the vibrators against falling by means of a safety cable.

7 Start-up and operation



Observe the safety instructions in chap. Safety, starting on page 3.

Permissible operating conditions

Please refer to chap. Technical data, page 4 for permissible operating conditions.

Set frequency

Set the centrifugal force or frequency required with an upstream pressure regulator. For this purpose, slowly increase the pressure from approx. 1.5 bar to the required or necessary centrifugal force.

The maximum permissible frequency or maximum permissible operating pressure must not be exceeded. The frequency can be measured with a *VibroScanner* or sirometer (optionally available from *NetterVibration*).

After 30 minutes operating time: check if the initial frequency is still set. Adjust the frequency if required.

Frequency / bearing life NCT

NCT 1 and NCT 2: Due to high efficiency they reach very high frequencies. The high frequencies reduce the bearing life and increase the sound level. Therefore, *NetterVibration* recommends operating the NCT 1 and NCT 2 only at 2 - 3 bar or only in interval operation.

NCT: operation in liquids

The operation of NCT in liquids requires the discharge of the compressed air into the atmosphere.

NCR..M 1 and NCR..M 500: operation in high ambient temperatures

When operating in high ambient temperatures, the use of a mist lubricator with a special high-temperature lubricant (up to max. 300 °C) extends the service life of the NCR..M 1 and NCR..M 500.

8 Maintenance and servicing



Observe the safety instructions in chap. Safety, starting on page 3.

Cleaning

Clean the surface of the vibrators regularly with a moist cloth to remove dust deposits.

To clean the vibrators with pressurised water, proceed as follows:

1. Unscrew the silencer and close the exhaust air opening.
2. Clean the vibrators externally with pressurised water.
3. Mount the silencer.
4. Activate the vibrators briefly.

Bearings (NCT)

Damaged or worn bearings may be replaced by *NetterVibration*.

Maintenance plan

Interval	Action
After an hour of operation after initial start-up	Check fastening screws.*
	Check hose screw connections and hose connections and retighten, if necessary.
Monthly	Check fastening screws.*
	Check hose screw connections and hose connections and retighten, if necessary.
	Check hose supply lines for permeability and kinking. If necessary, clean and remove kinks.
	Check the function of the silencer. Replace it if necessary. A clogged silencer causes a loss of performance. In extreme cases it can lead to the complete failure of the vibrators.
	Check frequencies and set, if necessary.
	Empty filter of maintenance unit, if necessary. Clean (wash out) filter element and replace, if necessary.
	Check the function of the mist lubricator. Refill oil if necessary.
If necessary	Clean vibrators.

* Observe the tightening torques (see chap. Technical data, from page 4 on).

Maintenance intervals

The maintenance intervals depend essentially on the operating conditions, the service life and how clean the drive medium is. Unfiltered compressed air leads to high wear, silencer clogging or complete failure of the vibrators.

9 Troubleshooting



Observe the safety instructions in chap. Safety, starting on page 3.

Malfunction	Possible cause	Corrective action
Vibrator has too little power or does not start	Connections switched	Place the air inlet on the connection with the smaller bore (see arrows).
	Dimensioning	Check size of the vibrator. Is the size correct?
	Pressure too low	Check pressure in front of Vibrator. Nominal width of hoses and valves observed? Lines kinked?
	Silencer clogged	Clean or replace silencer.
Power loss	Pressure on vibrator	Set operation pressure. Caution: Observe max. frequency.
	Air line kinked	Connect the compressed air supply line without kinks.
	Leakage in air line	Replace the compressed air supply line.
	Silencer clogged	Clean or replace silencer.
	Wear, pollution	Have vibrator checked by NetterVibration .
Only NCT: Significant power loss, loud noise from bearings	Damage to bearings	Have NCT checked by NetterVibration .
Unusual rise in sound level after prolonged operating time	Loose construction parts or screws (rattling)	Secure loose parts, tighten screws.

10 Disposal

All parts of the vibrators must be properly disposed of according to the material specifications. The vibrators can be properly disposed by **NetterVibration**. The valid disposal prices are available on request.

Material specifications

Material	Part
Aluminium	Housing (except for S-versions and NCR..M-versions) / NCT: turbine, bearing cover / NCR: cover (except for NCR M-versions)
Steel, steel galvanized	Screws / NCB: steel ball, ball race, pin and cover NCR: steel roller and inner ring NCR M-versions: housing, cover
Tungsten alloy	NCT: unbalances
Plastics	Silencer (except for HT- and M-versions) / NCB: O-ring
Stainless steel	NCT S: housing, bearing cover
Sintered metal	For HT- and M-versions: silencer
Brass	For NCT 1 and 2: turbine / For HT-versions: hose grommet