

These operating instructions apply to:

NHK 10
NHK 25 M60



Contents

1	General information	3
2	Safety	5
3	Technical data	7
4	Design and function	10
5	Transport and storage	11
6	Installation	12
7	Start-up and operation	15
8	Maintenance and servicing	17
9	Troubleshooting	18
10	Spare parts and accessories	19
11	Disposal	20
12	Annex	21

Scope of delivery	Please refer to the delivery note for the scope of delivery. Check the packaging for possible transport damage. In the event of damage to the packaging, check the contents for completeness and possible damage. Inform the carrier in the case of damage.	
Designation	The high-frequency impactors of the series NHK are hereafter referred to as "NHK".	
Version of document	Document no.	1684E
	Version no.	5
	Date of issue	April 2026

1 General information

Use and storage	Before installing the NHK read these instructions carefully. It is the basis for any action when dealing with the NHK, and may be used for training purposes. The instructions should be subsequently stored at the operation site.
Target group	<p>The target group for these instructions is technical staff, who have basic knowledge in pneumatics and mechanics.</p> <p>Only complying technical staff may work on the NHK.</p> <p>The NHK may only be installed, put into operation, maintained, troubleshot and disassembled by persons authorised by the operator.</p>
Copyright	<p>This documentation is protected by copyright.</p> <p>NetterVibration reserves all rights such as translations, reprinting and reproduction of the instructions, as well as parts thereof.</p>
Limitation of liability	<p>All technical information, data and instructions for installation, operation and maintenance in these instructions are based on the latest information available at the time of printing and take our past experience to the best of our knowledge into account.</p> <p>No claims can be derived from the information, illustrations and descriptions in these operating instructions.</p> <p>The manufacturer does not assume liability for damages resulting from:</p> <ul style="list-style-type: none">• failure to observe the instructions,• improper use,• unauthorised repairs,• technical modifications,• use of non-permissible spare parts. <p>Translations are made to the best of our knowledge.</p> <p>NetterVibration does not assume liability for translation errors, even if the translation was made by us or on our behalf. Only the original German text remains binding.</p>
Directives / standards observed	<p>The high-frequency impactors of the series NHK comply with the following directives and regulations:</p> <ul style="list-style-type: none">• EC Machinery Directive 2006/42/EG• Supply of Machinery (Safety) Regulations 2008 (UK) <p>In particular, the standard EN ISO 12100 has been observed.</p>

Instruction and warning symbols

The following instruction and warning symbols are used in these instructions:

Personal injuries

⚠ DANGER

	<p>indicates an immediate danger. Disregard of this notice will result in death or severe personal injuries.</p>
---	--

⚠ WARNING

	<p>indicates a potential danger. Disregard of this notice can result in death or severe personal injuries.</p>
---	--

⚠ CAUTION

	<p>indicates a potentially dangerous situation. Disregard of this notice can result in minor or moderate personal injuries.</p>
---	---

Material damages

NOTICE

<p>indicates potential material damage. Disregard of this notice can result in material damage.</p>

Notes

IMPORTANT

<p>indicates actions, methods or notes that are not relative to safety, e.g. useful information and tips.</p>

	<p>Environmentally safe disposal indicates the obligation of environmentally safe disposal.</p>
---	--

2 Safety

Intended use

General areas of application of the NHK are for cleaning very sticky materials from components (e. g. container walls, rotary kilns, heat exchangers) as well as for removing cast parts from moulds.

The NHK are designed for installation in machines and may only be put into operation, if it has been assured that the complete machine complies with the regulations of the machinery directive.

The NHK may also be used outdoors and in dusty and humid environments. The NHK may not be submerged in bulk materials or in liquids.

NHK may only be operated clocked.

Any other use is considered improper.

Qualification of qualified personnel

Installation, commissioning, maintenance and troubleshooting of the NHK may only be performed by authorised qualified personnel, who have basic knowledge in pneumatics and mechanics.

All handling of the NHK is the responsibility of the operator.

Compressed air

⚠ WARNING	
Compressed air	
A loosened hose which is under pressure can lead to personal injuries.	
<ul style="list-style-type: none"> ➤ Screw the hose lines on carefully. ➤ Check the hose lines and connections after one hour of operation and thereafter regularly (generally monthly). ➤ Retighten the hose lines, if necessary. ➤ Ensure that the compressed air is disconnected from the supply lines during all work on the NHK. ➤ Prevent the NHK from being switched back on during all work. 	

Sound level

⚠ WARNING	
	Sound level Near the NHK or in the vicinity of the constructions connected with the NHK, the sound pressure level may exceed 80 dB(A). The human ear can be permanently damaged by the high sound level. <ul style="list-style-type: none"> ➤ When working in the noise area, use ear protection if 80 dB(A) is exceeded.

Falling parts

⚠ WARNING	
	<p>Falling parts</p> <p>The NHK, construction parts as well as fastening and housing screws can come loose due to vibration. Falling parts lead to severe personal injuries.</p> <ul style="list-style-type: none"> ➤ Check the fastening and housing screws after one hour of operation and thereafter at regular intervals (generally monthly). ➤ Retighten the fastening and housing screws, if necessary. ➤ A safety device with a safety cable is mandatory for critical mounting situations.

Heavy parts

⚠ WARNING	
<p>Risk of injury while handling heavy parts</p> <p>Risk of serious injury due to weight during transport and installation of the NHK.</p> <ul style="list-style-type: none"> ➤ Observe the weight information in chap. Technical data, starting on page 7. ➤ Only qualified personnel may transport and install the NHK. ➤ Use suitable load handling devices and slinging equipment. ➤ Wear suitable personal protective equipment. 	

Striking of impact mass

NOTICE	
<p>Striking of impact mass on the flange</p> <p>The NHK has no independent protection against striking of the impact mass on the flange. If the impact mass strikes on the flange, the NHK can be destroyed.</p> <ul style="list-style-type: none"> ➤ Make sure that the impact mass does not rest on the flange during operation. Observe the information in Chapter Installation, page 13. ➤ Actuate the NHK only in a mounted condition. 	

3 Technical data

Permissible operating conditions

Drive medium	NHK must be operated with lubricated compressed air or lubricated nitrogen according to the following specification: ISO 8573-1 [5 : 6 : 4] Filter ≤ 5 µm Humidity, Pressure dew point ≤ +10 °C Total oil content ≤ 5 mg/m ³ NHK L versions are suitable for operation with oil-free, dried compressed air according to the following specification: ISO 8573-1 [5 : 6 : 2]	
Lubricant	ISO viscosity class in accordance with DIN ISO 3448, VG 5 to 15 Fill mist lubricator with acid- and resin-free as well as temperature-resistant compressed air oil. Recommended Settings: NHK 10: 1-2 drops/min NHK 25: 3-4 drops/min	
	Recommendation for temperatures of up to 60 °C: Klüber "AIRPRESS 15"	Recommendation for temperatures above 60 °C: Castrol Perfecto HT 5
Ambient temperature*	Standard versions: 5 °C to 160 °C	
Operating pressure*	2.0 to 6.0 bar	
Clocked operation*	The individual working interval of the NHK must not exceed 5 seconds, after which a pause of at least 10 seconds must follow. The maximum working time is 60 s/h.	

* Higher operating pressures and temperatures as well as longer working intervals are permitted only after consultation with and written consent by the application technicians of NetterVibration.

Service life

The technical performance data changes over the service life (wear and contamination).

Sound level

The sound level is largely determined by the contact surface onto which the NHK strikes. The sound pressure level of the NHK may exceed 80 dB(A). Non-insulated sheets increase the sound level.

The sound emitted by the NHK can be dampened by coverings. The sound pressure level is reduced only with simultaneous insulation of the applied sheets.

Technical data for drive unit

As a drive unit the NHK contains a vibrator of the type NTS, for which the following information applies:

Momentum [cmkg]			Nominal frequency [min ⁻¹]			Centrifugal force [N]			Air consumption [l/min]	Sound level [dB(A)]
2 bar	4 bar	6 bar	2 bar	4 bar	6 bar	2 bar	4 bar	6 bar	2 - 6 bar	2 - 6 bar
NHK 10:										
1,01	1,31	1,44	2.848	3.596	4.038	451	934	1.291	99 - 442	67 - 81
NHK 25:										
7,9	9,8	9,7	1.920	2.296	2.672	1.591	2.844	3.789	271 - 977	77 - 86

The technical data are comparative values and can vary depending on the application. Further data on request.

Dimensions and weight

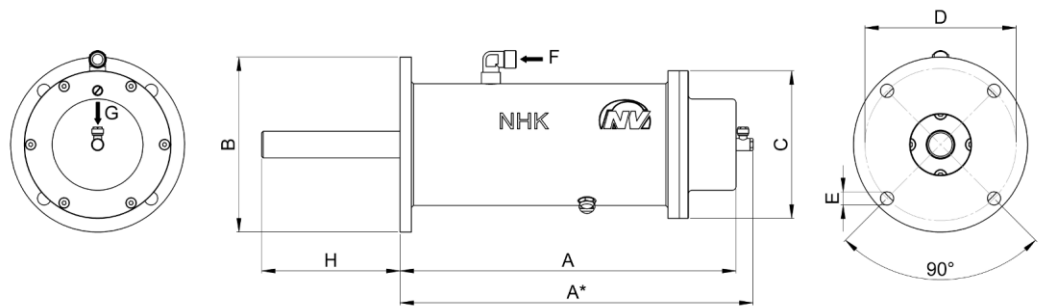

A [mm]	A* [mm]	B [mm]	C [mm]	D [mm]	E [mm]	F [inch]	G [inch]	H [mm]	Weight [kg]
NHK 10									
268	287	180	160	152	13	G 1/4	G 1/4	0 - 150	16*
NHK 25									
444	466,5	230	194	200	17,5	G 1/2	G 1/8	153 - 213	35**

* Weight with rod is 19 kg.

** Weight with rod is 38 kg

Minimum cross-sections valves / hoses

Type	Connection thread [inch]	3/2-way valve [inch]	Hose size (thread and valve) *
NHK 10			
Drive unit	G 1/4	G 1/4	DN 6
Pneumatic preload pressure	G 1/4	G 1/4	DN 6
NHK 25			
Drive unit	G 1/2 × 15	G 1/2	DN 12
Pneumatic preload pressure	G 1/8 × 8	G 1/4	DN 6

* DN = diameter nominal (inner diameter)

Tightening torques

NetterVibration recommends the following tightening torques for fastening screws and nuts of the strength class 8,8 (sliding friction coefficient 0.14):

Type	Thread	Tightening torque [Nm]	Minimum screw depth for tapped hole in S 235 JR * [mm]
NHK 10	M12	86	16
NHK 25	M16	210	27

* Material S 235 JR = St 37-2, minimum screw depth for other materials on request

Always use a torque wrench and tighten the screws crosswise.

4 Design and function

Design

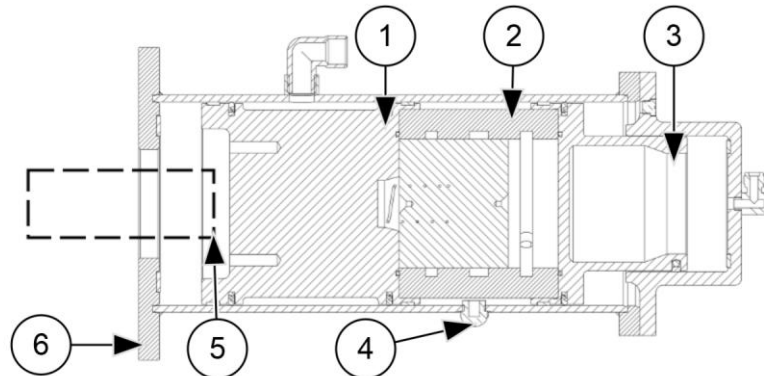

- | | |
|--|---|
| 1 Impact mass | 4 Silencer |
| 2 Pneumatic linear vibrator series
NTS/
drive unit | 5 Contact surface/
intersection provided by customer |
| 3 Pneumatic preload pressure | 6 Flange |

Function

In the housing of the NHK there is an axially movable impact mass (1), which is driven by a pneumatic linear vibrator (2).

The unit of impact mass and linear vibrator is pressed on the contact surface (5) by means of the pneumatic preload pressure (3). The contact surface thereby has to extend to the housing of the NHK.

The preload pressure is adjustable and determines the operating mode of the NHK: bounce impacts or linear vibrations.

If the preload force of the impact mass is chosen smaller than the centrifugal force of the linear vibrator, the NHK generates high-frequency bounce impacts acting on the mounting surface.

If the chosen preload force exceeds the centrifugal force of the linear vibrator, the NHK generates linear vibrations.

Rod kit

The impact mass of the NHK is by default prepared for operation with a rod. The rod transmits linear vibrations or bounce impacts to the component.

Rod retraction kit

The rod retraction kit pulls the rod and the inner components of the NHK into the rear end position.

Rod guidance kit

The rod guidance kit is used to absorb transverse forces that act on the rod.

5 Transport and storage

Transport conditions

Special conditions of transport are not required.

Packaging

The NHK are packed and ready for assembly. Accessories and add-on parts are delivered unmounted, unless otherwise agreed upon.

The packaging protects the NHK from transport damage. The packaging material has been selected from an environmentally safe and technically disposable point of view and is therefore recyclable.

The return of packaging to the material cycle conserves raw materials and reduces the amount of waste.

Storage conditions

- Store the NHK in a dry and clean environment.
- Protect the NHK from UV-exposures, weather and ozone.
- The storage temperature is between 5°C and +60°C.
- Close all openings when re-storing.

NetterVibration recommends storage at a constant storage temperature and humidity.

- Preserve all NHK apart from the NHK L before storage:
 1. Add anti-corrosion oil to the air inlet of the NHK.
 2. Actuate the NHK briefly when mounted.
 3. Then close the supply air connections of the NHK.

6 Installation



Observe the safety instructions in chap. Safety, starting on page 5.

Technical data Information regarding tightening torques for screws as well as cross sections for valves and hoses can be found in chap. Technical data, starting on page 7.

Fastening *Example: NHK without rod kit*

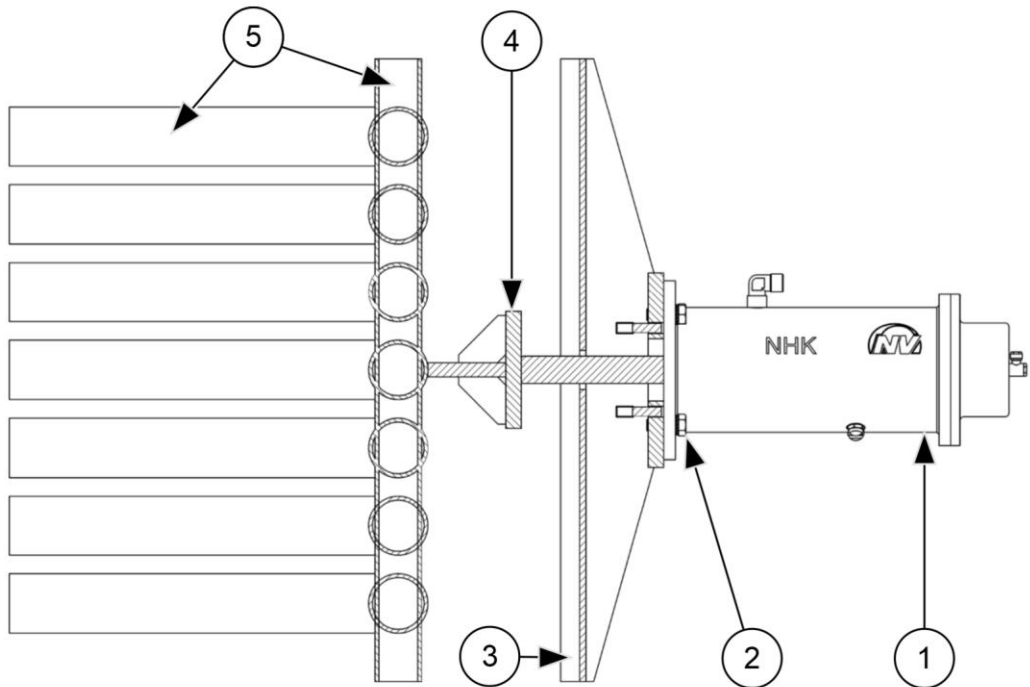

- | | | | |
|---|-------------------------------------|---|---------------------------------|
| 1 | NHK | 4 | Rod device provided by customer |
| 2 | Fastening screw | 5 | Heat exchanger |
| 3 | Container wall with weld-on console | | |

Mount the NHK (1) with the supplied fastening screws (2) on a suitable mounting surface (± 0.1 mm flatness).

Observe the recommended values for screw sizes and tightening torques. If the mounting surface is mechanically connected to the component (5) to be vibrated (e. g. to be cleaned), usage of the fastening kit NBS is recommended (available on request).

Position of the impact mass

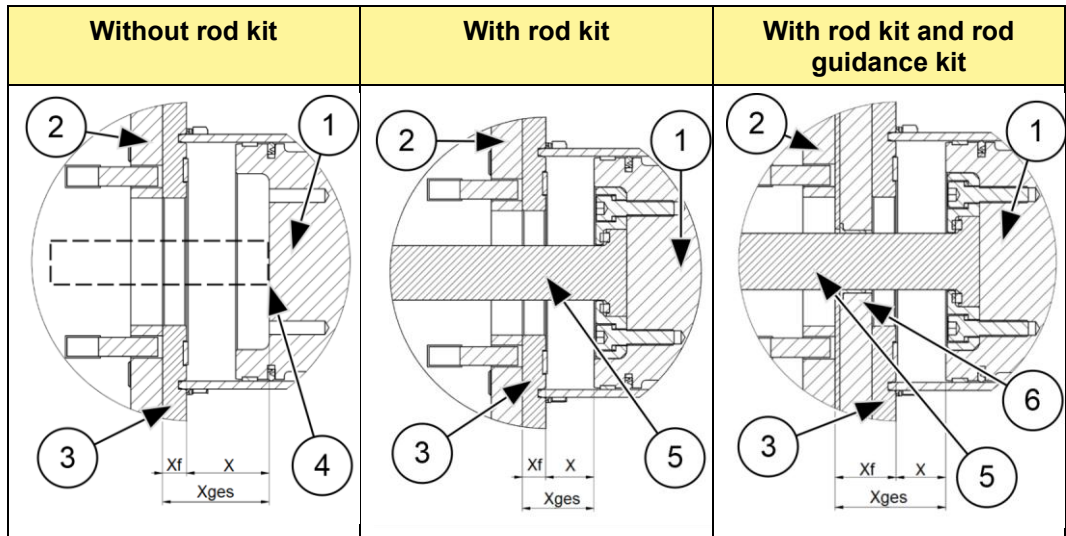

- 1 Impact mass
- 2 Fixing device
- 3 Flange
- 4 Intersection provided by customer
- 5 Rod
- 6 Rod guidance

The NHK has no independent protection against striking of the impact mass on the flange. Therefore, the compliance of the following gap X_{ges} between flange and impact mass varying depending on the configuration of the NHK has to be ensured:

Configuration:	Xf [mm]	X [mm]	Xges* [mm]
NHK 10 ...			
without rod kit	5	21 - 51	26 - 56
with rod kit	5	5 - 35	10 - 40
with rod kit and rod guidance kit	27	5 - 35	32 - 62
NHK 25 ...			
without rod kit	15	31 - 72	46 - 87
with rod kit	15	10 - 50	25 - 65
with rod kit and rod guidance kit	38	10 - 50	68 - 88

* measured from the outside of the flange (see illustration)

Standard installation

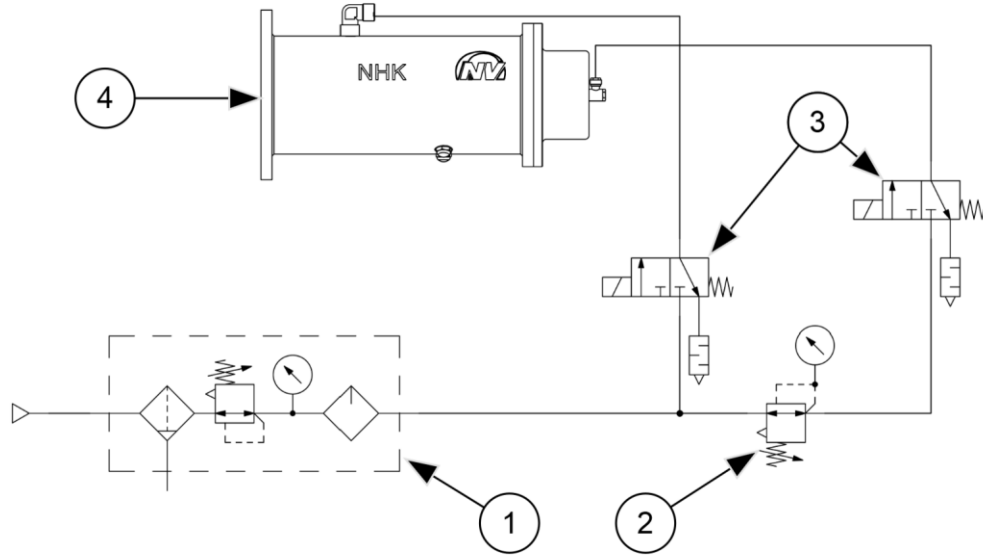

- | | | | |
|---|--|---|---------------|
| 1 | Maintenance unit
(NHK L: without mist lubricator) | 3 | 3/2-way valve |
| 2 | Pressure regulator with manometer | 4 | NHK |

Air supply

The loss of pressure increases with hose length. The nominal diameters in chap. Technical data, starting on page 7, apply to hose lengths up to 3 m. Longer supply lines require larger cross-sections.

Checklist installation

Check that the following steps have been carried out:

- Compliance with permissible ambient temperatures ensured?
- NHK mounted on suitable mounting surface (± 0.1 mm flatness) with the supplied fastening screws/the fastening kit NBS?
- Position of the impact mass checked?
- Details on hose length and nominal width observed?
- Maintenance unit (filter, mist lubricator, pressure regulator; NHK L: filter, pressure regulator), way valve, pressure regulator with manometer and air supply lines installed?
- NHK secured against falling down in critical installation situations by means of a safety cable?

7 Start-up and operation



Observe the safety instructions in chap. Safety, starting on page 5.

Permissible operating conditions

Please refer to chap. Technical data, page 7 for permissible operating conditions.

Stroke energy

At a stroke rate of up to 50 strokes/s, NHK generate up to 15 J of impact energy.

Setting pressure regulator

After mounting the NHK, adjust frequency and preload pressure as follows:

1. Set the preload pressure for the compressed air on the upstream pressure regulator to 6 bar.
2. Set the frequency by setting the operating pressure on the pressure regulator of the maintenance unit to 2 to 6 bar.
Note that by reducing the frequency, the centrifugal force of the drive unit is reduced as well, whereby the resulting impact energy during operation with bounce impacts is reduced. Moreover, the preload pressure has to be adjusted to the centrifugal force of the drive unit.
3. Slowly reduce the preload pressure on the upstream pressure regulator while the NHK is running until homogenous bounce impacts are generated by the NHK.

Note: For operation with linear vibrations the preload pressure must not be reduced.

Setting mist lubricator (except for NHK L)

Set the mist lubricator to the smallest safely adjustable number of drops while the NHK is running. **Notice:** The NHK is ready for operation only after adjustment and correct functioning of the mist lubricator.

Please refer to Ch. Technical data, page 7 (Lubricant) for the recommended number of drops.

**Checklist
start-up**

Check that the following steps have been carried out:

Hose connections checked before installation?

Desired operating pressure set on pressure regulator of maintenance unit?

Mist lubricator set (except for NHK L)?

For operation with bounce impacts:

Preload pressure on the upstream pressure regulator adjusted in such a way that homogeneous bounce impacts are generated by the NHK?

After one hour of operation:

Hose lines as well as fastening and housing screws checked and retightened, if necessary?

Then follow the maintenance plan.

8 Maintenance and servicing



Observe the safety instructions in chap. Safety, starting on page 5.

Maintenance plan

Maintenance of the NHK must be carried out as follows:

Interval	Action
After one hour of operation after initial start-up	Check fastening and housing screws.
	Check hose screw connections and hose connections and retighten, if necessary.
Monthly	Check fastening and housing screws.
	Check hose screw connections and hose connections and retighten, if necessary.
	Check hose lines for permeability and kinks. If necessary, clean and remove kinks.
	Check the function of the silencer.
	Check the operating mode, adjust the preload pressure, if necessary.
	Ensure that the mist lubricator operates according to the regulations (see Ch. Technical data, page 7 (Lubricant) for setting). Refill oil, if necessary (except for NHK L).
Clean the filter of the maintenance unit and replace, if necessary.	
At the latest after a total operating time of 1000 hours	Carry out the general overhaul, in which all wear parts must be replaced.

Implementation by Netter

Maintenance, repair and general overhaul of the NHK may alternatively be performed by **NetterVibration**.

Maintenance intervals

The maintenance intervals depend essentially on the service life and how clean the drive medium is.

The maintenance intervals are shortened with the operating hours of the NHK.

- In particular, increased abrasion can form a coating in the oil-free and/or dried compressed air operated NHK L, which impairs the function.
- Unfiltered compressed air leads to high wear, blockage of the silencer or complete breakdown of the NHK.

9 Troubleshooting

Malfunctions and causes

In the case of malfunctions of the NHK proceed as follows:

Disturbance	Possible cause	Corrective action
No start	Silencer polluted	Clean silencer.
	Compressed air supply	Check if there is enough pressure at the NHK. Check valve. A 3/2-way valve is mandatory, so that the supply line to the NHK is vented.
	Wire cross-section	Note minimum cross-sections (see Ch. Installation, page 9).
	Line too long between valve and NHK	If necessary, place controlled 3/2-way air valve before the NHK.
	Exhaust air throttled too much	Check silencer.
	Tension during installation	Ensure a flat mounting surface.
	Unsuitable way valve	Use a 3/2-way valve with sufficient cross-section.
Rattling	Loose screws	Check fastening and housing screws.
Power loss	Lubrication missing	Check the function of lubricator (except for NHK L).
	NHK polluted	Disassemble, remove coating.
	Wear	Check drive unit for visible wear. If worn, send NHK in (see note in Ch. Spare parts and accessories; page 19).
	Operating pressure too low	Check the pressure at the inlet of the NHK during operation. Increase the operation pressure, if necessary. Check wire cross-sections.
	Unsuitable preload pressure	Check preload pressure settings. Increase or decrease the preload pressure, if necessary.
Severe vibrations at the housing	Unsuitable mounting method	Use the fastening kit NBS.
	Striking of impact mass on the flange	Control and adjust, if necessary, the gap between impact mass and flange (see Ch. Installation, page 13).

10 Spare parts and accessories

Ordering of spare parts

Please provide the following details when ordering spare parts:

- type of NHK
- description and position of spare part
- required amount

Joint delivery

IMPORTANT

Please take note: Piston and housing of the drive unit are produced pairwise and can only be delivered together.

Possible accessories

Following accessories for the NHK are available:

Component	Description
Hose material and hose screw connections	Available for air supply (operation air, control air), in different qualities and dimensions
3/2-way valves	Electric, pneumatic, manual
Maintenance units	Filter, pressure regulator with manometer, mist lubricator or filter and pressure regulator for NHK L
Netter Electronic Timers	Electric or pneumatic, for interval operation
Fixing devices	For permanent fixing
Safety cable	For critical mounting situations
Control cabinet NSS-PX	For controlling one or several NHK
Fastening kit NBS	Recommended for safe and permanent mounting in case of assembly directly on the component to be vibrated (see Ch. Installation, page 12)
Rod kit	For transmitting the vibration of the NHK without an intersection provided by customer
Rod retraction kit	Pulls the rod and the inner components of the NHK into the rear end position; only in combination with control cabinet NSS-PX
Rod guidance kit	For absorbing additional forces acting on the rod of the NHK; only in combination with rod kit

11 Disposal

Prices

	<p>All parts of the NHK must be properly disposed of according to the material specifications. The valid disposal prices of the NHK are available on request.</p>
---	---

Material specifications

All parts of the NHK can be recycled.

Material	Part
Aluminium	Housing of the NTS, top cover
Steel	Housing, flange, impact mass, piston, springs, screws
Plastics	Seals, dampers

12 Annex

The declaration of incorporation can be found at: www.NetterVibration.com